

2ME S

(WITH INTEGRATED SINGLE-PHASE MOTOR)

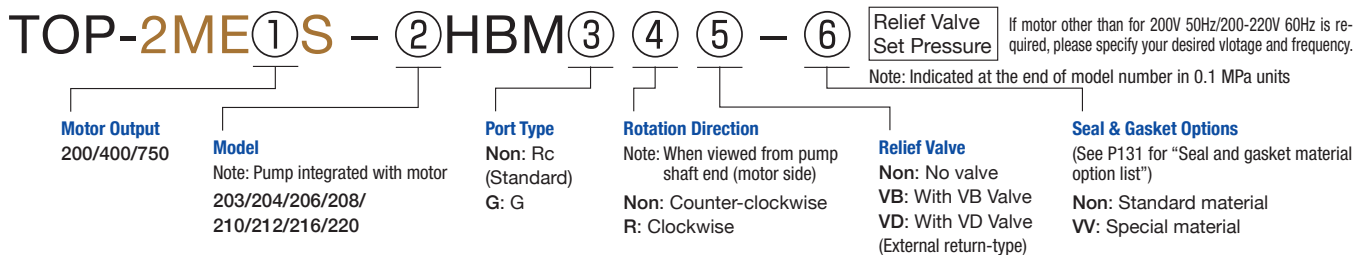

Model Numbering System



Specifications

Model	Item	Motor speed 50Hz 1500min ⁻¹			Motor speed 60Hz 1800min ⁻¹				
		Theoretical discharge (ℓ/min)	Max. pressure for motor output (MPa)			Theoretical discharge (ℓ/min)	Max. pressure for motor output (MPa)		
			200W	400W	750W		200W	400W	750W
TOP-203HBM		4.2	1.7	3.0	3.0	5.0	1.3	3.0	3.0
TOP-204HBM		6.0	1.2	3.0	3.0	7.2	0.9	2.3	3.0
TOP-206HBM		9.0	0.7	1.8	2.5	10.8	0.5	1.4	2.5
TOP-208HBM		12.0	0.5	1.3	2.5	14.4	0.3	1.0	2.3
TOP-210HBM		15.0	0.4	1.1	2.5	18.0	0.3	0.9	2.0
TOP-212HBM		18.0	0.3	0.9	2.0	21.6	–	0.7	1.6
TOP-216HBM		24.0	0.2	0.7	1.5	28.8	–	0.5	1.2
TOP-220HBM		30.0	–	0.4	1.2	36.0	–	0.3	0.9

• Test oil: ISO-VG46/Oil temperature: 40C

Motor Specifications

- Single-phase induction motor
- Open drip-proof
- condenser-starting type
- Class E insulation (200W 400W)
- Class F insulation (750W)
- Protection level IP22

Output (W)	Number of poles (P)	Rating	Voltage (V)	Frequency (Hz)	Motor Speed (min ⁻¹)	Current (A)	Approx. Weight (Kg)
200	4	Cont	100	50	1450	6.4	9
				60	1740	5.2	
			200	50	1450	3.2	
				60	1740	2.6	
400	4	Cont	100	50	1410	8.8	13
				60	1690	8.0	
			200	50	1410	4.4	
				60	1690	4.0	
750	4	Cont	100	50	1420	11.0	16
				60	1710	10.6	
			200	50	1420	5.5	
				60	1710	5.3	

Note: There are no models compatible with Increased safety and outdoor use in 2ME series.

Any disassembly or alteration of the product will void the warranty.

■ Dimensions (Typical) for 2ME S

Model : TOP-2ME200S-2**HBMVB-**

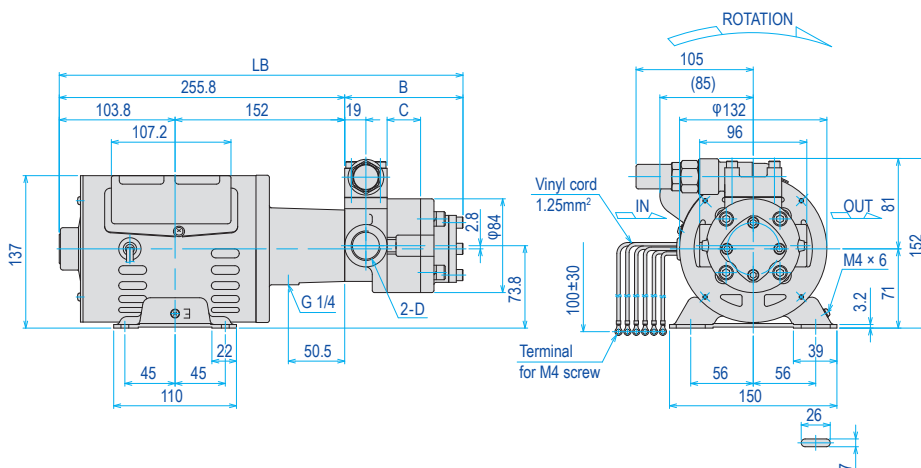

CONNECTION DIAGRAM

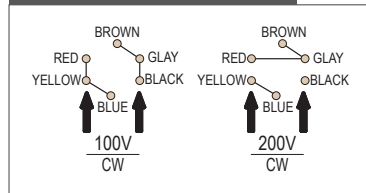

Model	Item	LB	B	C	D
203		338.8	83	7	Rc 1/2
204		341.8	86	10	
206		346.8	91	15	
208		351.8	96	20	
210		356.8	101	25	Rc 3/4
212		361.8	106	30	
216		371.8	116	40	

Model : TOP-2ME400S-2**HBMVB-**

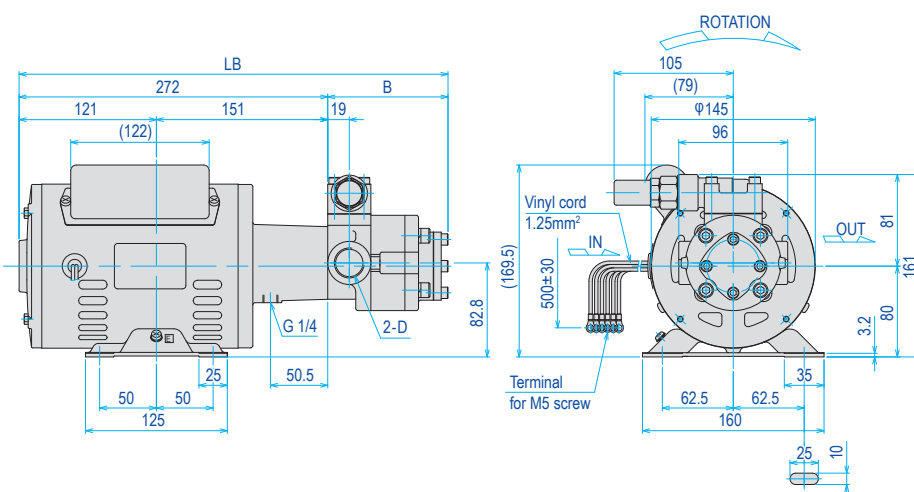

CONNECTION DIAGRAM

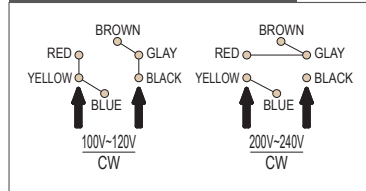

Model	Item	LB	B	C	D
203		355	83	7	Rc 1/2
204		358	86	10	
206		363	91	15	
208		368	96	20	
210		373	101	25	Rc 3/4
212		378	106	30	
216		388	116	40	
220		398	126	50	

Model : TOP-2ME750S-2**HBMVB-**

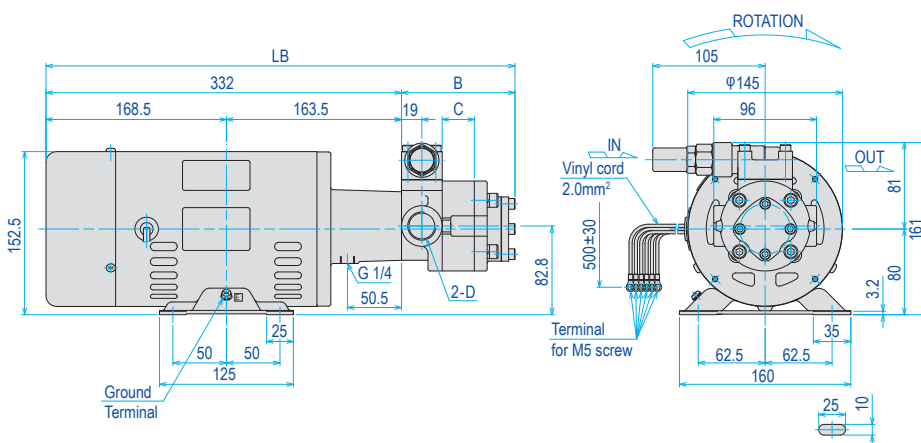

CONNECTION DIAGRAM

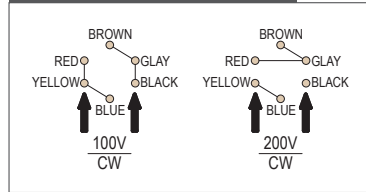

Model	Item	LB	B	C	D
203		415	83	7	Rc 1/2
204		418	86	10	
206		423	91	15	
208		428	96	20	
210		433	101	25	Rc 3/4
212		438	106	30	
216		448	116	40	
220		458	126	50	