

4MB-4AM

(BASE-COUPLING MOUNT TYPE)

4AM

(PUMPHEAD)

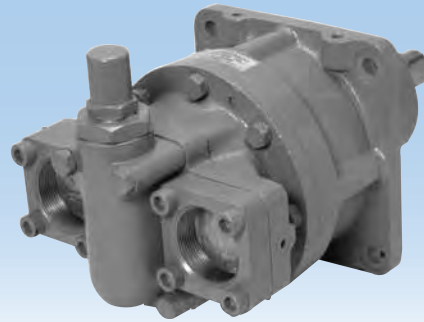

Model Numbering System (For General Lubricant Oil)

TOP-4MB ① ② - 6 - ③ ④ **VB** - ⑤

Relief Valve Set Pressure If motor other than for 200V 50Hz/200-220V 60Hz is required, please specify your desired voltage and frequency.
 Note: Indicated at the end of model number in 0.1 MPa units

<p>Motor Manufacturer M (Mitsubishi) T (Toshiba)</p>	<p>Motor Output 3700/ 5500/ 7500 Note: "IE3" is added at the end of model no.</p>	<p>Model 4100AM/ 4130AM/ 4150AM/ 4200AM/ 4250AM</p>	<p>Rotation Direction Note: When viewed from pump shaft end (motor side) Non: Clockwise L: Counter-clockwise</p>	<p>Seal & Gasket Options (See P131 for "Seal and gasket material option list") Non: Standard material (fluororubber) VH: Special material</p>
---	--	--	---	--

Model Numbering System (Pumphead)

TOP- ① ② ③ **VB** - ④

Relief Valve Set Pressure
 Note: Indicated at the end of model number in 0.1 MPa units

<p>Model 4100AM/ 4130AM/ 4150AM/ 4200AM/ 4250AM</p>	<p>Attachment Non: No angle plate I: Angle plate</p>	<p>Rotation Direction Note: When viewed from pump shaft end Non: Clockwise (Standard) L: Counter-clockwise</p>	<p>Seal & Gasket Options (See P131 for "Seal and gasket material option list") Non: Standard material (fluororubber) VH: Special material</p>
--	---	---	--

Specifications

Model	Item	Theoretical displacement (cm ³ /rev)	Max. pressure (MPa)	Max. revolution (min ⁻¹)	Approx. Weight (Kg)
TOP-4100AM		115.5	2.0	1800	28.0
TOP-4130AM		148.5	2.0	1800	30.0
TOP-4150AM		171.6	2.0	1500	31.0
TOP-4200AM		231.0	2.0	1500	34.0
TOP-4250AM		280.5	2.0	1200	42.0

- Test oil: ISO-VG2/Oil temperature: 40C
- Add 9 Kg to the total weight if angle plate option is selected.

Specifications

Model	Item	Motor speed 50Hz 1000min ⁻¹			Theoretical discharge (ℓ/min)	Motor speed 60Hz 1200min ⁻¹				
		Theoretical discharge (ℓ/min)	Max. pressure for motor output (MPa)			Theoretical discharge (ℓ/min)	Max. pressure for motor output (MPa)			
			3700W	5500W			7500W	3700W	5500W	7500W
TOP-4100AM		115.5	1.1	2.0	2.0	138.6	0.8	1.5	2.0	
TOP-4130AM		148.5	0.8	1.5	2.0	178.2	0.6	1.1	1.6	
TOP-4150AM		171.6	0.7	1.3	1.4	205.9	0.4	0.9	1.2	
TOP-4200AM		231.0	0.4	0.8	1.1	277.2	0.2	0.6	0.7	
TOP-4250AM		280.5	-	0.6	0.9	336.6	-	0.4	0.6	

- Test oil: ISO-VG46/Oil temperature: 40C
- Number of poles : 6P

Any disassembly or alteration of the product will void the warranty.

■ Dimensions (Typical) for 4MB-4AM

Model : TOP-4MBT3700-6-4***AMIVB-** IE3

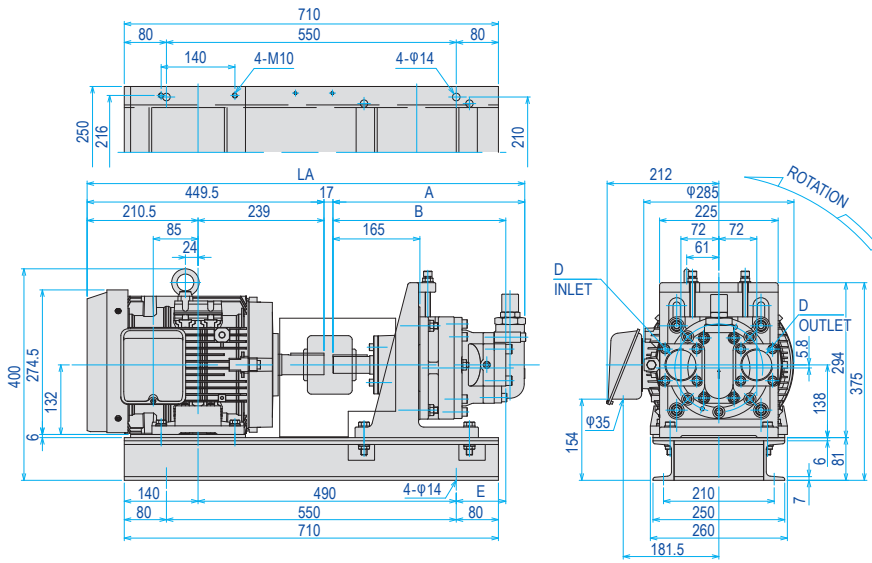

Item Model	LA	A	B	D	E
4100	820.5	354	318	Rc 1-1/2	84
4130	830.5	364	328	Rc 2	94
4150	837.5	371	335		101
4200	855.5	389	353		119

Model : TOP-4MBT5500-6-4***AMIVB-** IE3

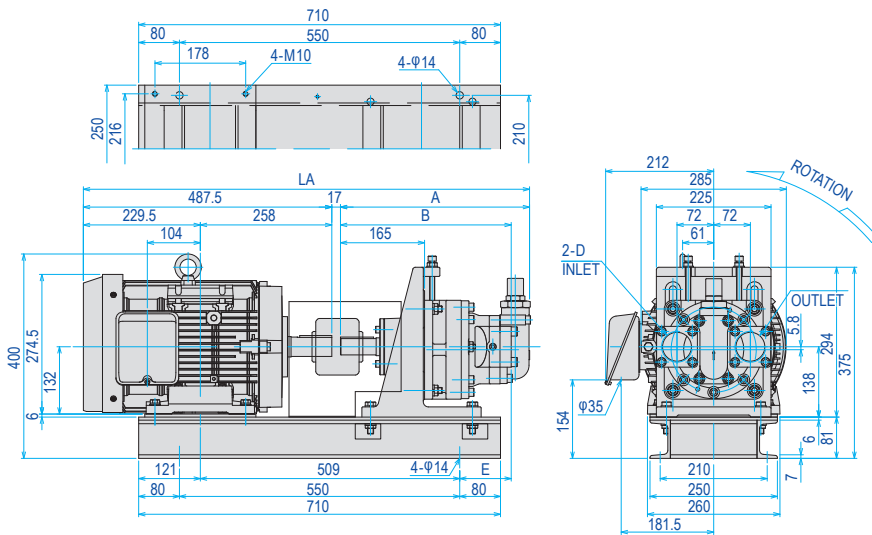

Item Model	LA	A	B	D	E
4100	858.5	354	318	Rc 1-1/2	84
4130	868.5	364	328	Rc 2	94
4150	875.5	371	335		101
4200	893.5	389	353		119
4250	908.5	404	368		134

Model : TOP-4MBT7500-6-4***AMIVB-** IE3

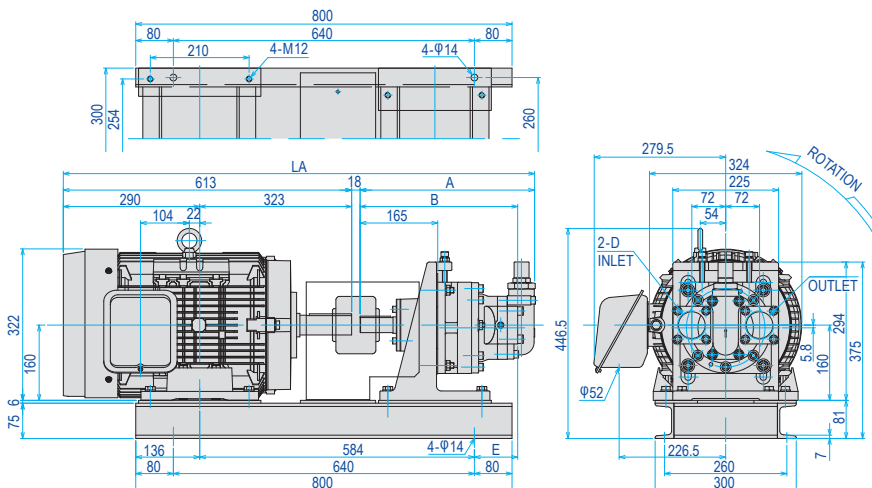

Item Model	LA	A	B	D	E
4100	985	354	318	Rc 1-1/2	75
4130	995	364	328	Rc 2	85
4150	1002	371	335		92
4200	1020	389	353		110
4250	1035	404	368		125

■ Dimensions (Typical) for 4AM

Model : TOP-4***AMVB-**

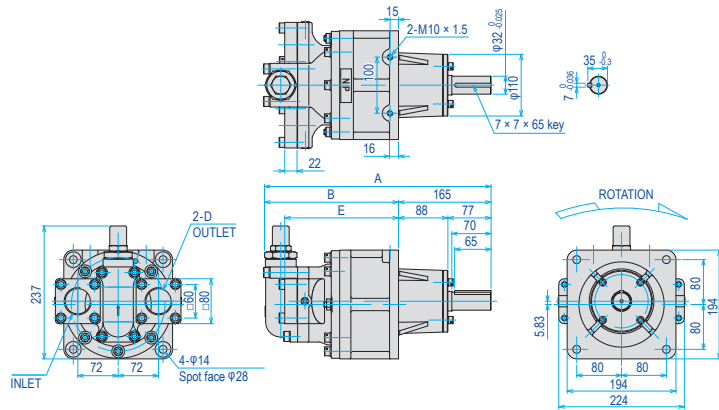

Item Model	A	B	D	E
4100	354	189	Rc 1-1/2	153
4130	364	199	Rc 2	163
4150	371	206		170
4200	389	224		188
4250	404	239		203

Model : TOP-4***AMIVB-**

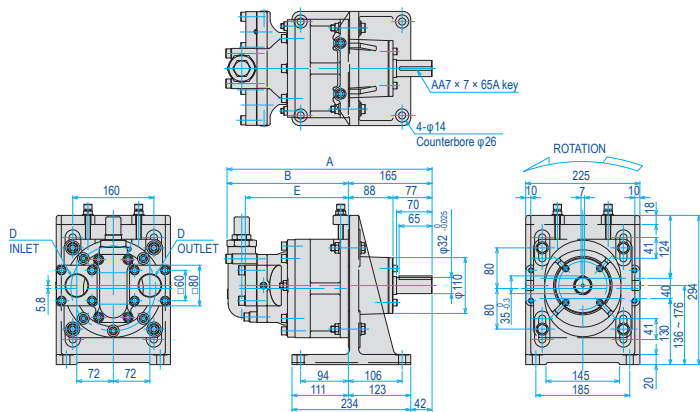

Item Model	A	B	D	E
4100	354	189	Rc 1-1/2	153
4130	364	199	Rc 2	163
4150	371	206		170
4200	389	224		188
4250	404	239		203

Model : TOP-4***AMLVB-**

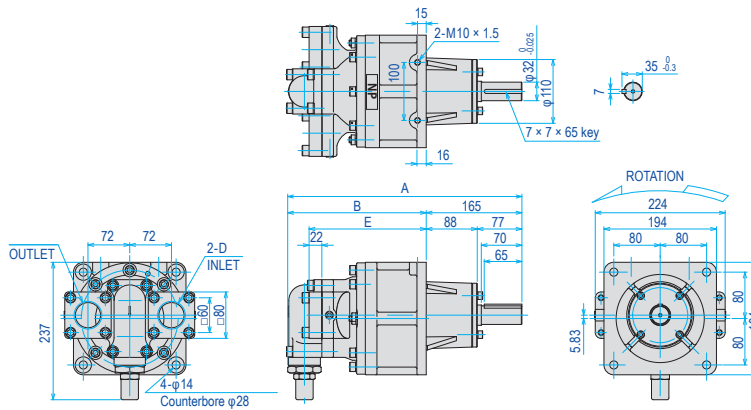

Item Model	A	B	D	E
4100	354	189	Rc 1-1/2	153
4130	364	199	Rc 2	163
4150	371	206		170
4200	389	224		188
4250	404	239		203

Model : TOP-4***AMILVB-**

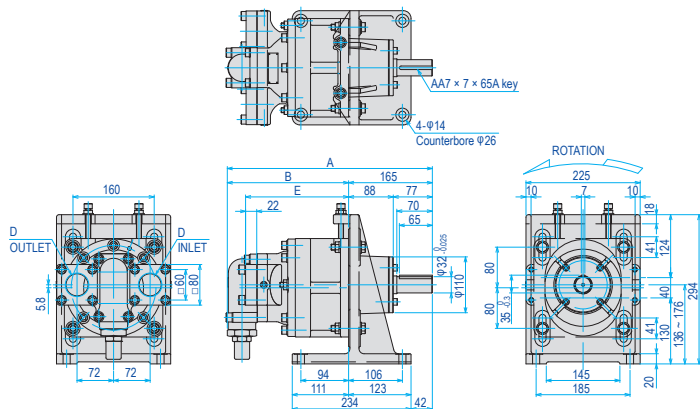

Item Model	A	B	D	E
4100	354	189	Rc 1-1/2	153
4130	364	199	Rc 2	163
4150	371	206		170
4200	389	224		188
4250	404	239		203

Any disassembly or alteration of the product will void the warranty.